

Quick Connects

Assembly Instructions

PN 10808

RECOMMENDED TOOLS



Wrenches or sockets:
M14 (or 9/16")
M15 (or 5/8")



Cordless Drill



Work Gloves



	Part Number	Description	Qty.
A	10808-1	Male Quick Connect (hook)	2
B	10808-2	Female Quick Connect (loop)	2
C	Hardware	M10x60mm Bolt/Nut	2

*Aluminum Quick Connects mount using existing Patriot Frame bolt/nuts. Mounting bolts not included. 4' End Rail (PN10803) required for both sides of connection.

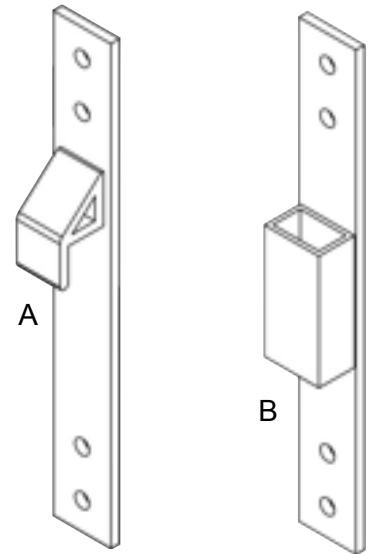

- 1 When installing Aluminum Quick Connects to a Patriot Brand Dock, each side of the connection must include a 4' Truss End Rail (PN10803). Ensure an End Rail exists on each side of the connection.

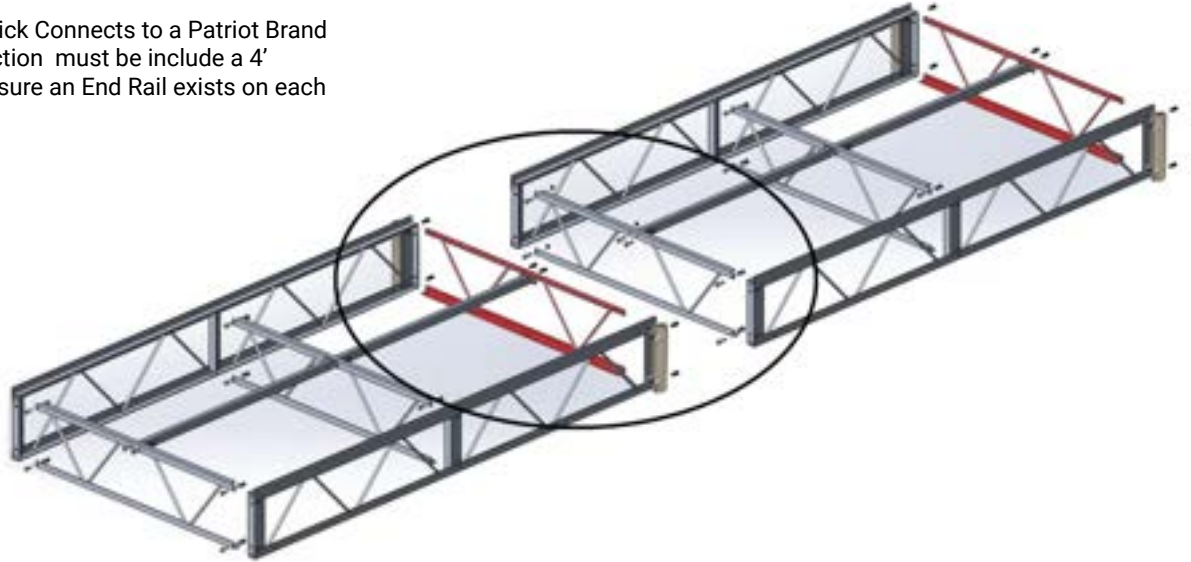

- 2 Install Female (B) Quick Connects to the **supported** side of the joint. Male (hook) Quick Connects will be installed on the **non-supported** side of the joint. Quick connects will share assembly hardware with PN10800 Patriot Dock Frame.



- 3 Once the supported section of dock is in the desired position, bring the second, un-supported section into position and align the hooks (male) over the loops (female). Drop the hooks into the loops.

Suggestion: After the Quick Connect pair is installed, use M10x60mm bolt/nut to make a hard connection between both frames as a lock. Each Quick Connect bracket has two extra holes (one on top and one on bottom). Install a M10x60mm bolt/nut on the top, through both frame and quick connect.

